

KIMAX 1



Installation- and Instruction Manual

Table of contents

| | |
|--|----|
| How does it work? | 3 |
| Air sensor installation..... | 5 |
| Hydraulic installation on a forklift | 8 |
| Electrical installation | 9 |
| Kimax 1 menu | 11 |
| Input menu (in) | 12 |
| AdL menu..... | 12 |
| Adh menu..... | 12 |
| Calibration..... | 13 |
| Alarms | 14 |
| Protecting your calibration..... | 15 |
| Daily use | 16 |
| Serial output..... | 17 |
| Troubleshooting | 18 |
| Dimensions and technical specifications..... | 19 |

Warranty

Kimax 1 cabin, trailer and hydraulic are all covered by Sense-Tech Weighing Systems ApS guarantee. Electronic failure and broken components caused by normal use are repaired or exchanged, when necessary, when sent to the factory.

Damage to your vehicle caused by installation of Kimax instruments or loss of time caused by recalibration or repairs of Kimax instruments are not covered by Sense-tech Weighing Systems ApS in any case.

Basic safety rules:

Before you start the installation procedure, make sure that the instrument has not suffered any damage during transport.

Note that the Kimax 1 instruments must be installed and connected in accordance with the regulations valid for the vehicle and country in question.

The Kimax 1 instruments must be protected from gravel, water spray from wheels and other factors that may damage the instruments.

We recommend mounting the instruments in a position where it is protected from water jets and rinse water.

Once you have decided where the instrument is to be mounted in the cabin, you must consider the cable routing.

Special attention should be given to potential damaging factors such as hinging points for tilting the cab.

Once you have decided where the instrument is to be mounted on the chassis, you must consider the cable routing.

Special attention should be given to tensile forces, cuts and other factors that may damage the cables and hoses.

Connection of compressed air.

Before you carry out any installation work related to the air suspension, make sure that the suspension has been brought to the lowest possible position.

Electrical connection

Always disconnect the battery before you perform any installation work on the system of the vehicle.

How does it work?

The Kimax 1 on board scale is an axle pressure gauge that uses pressure gauging on the air suspension to indicate the load, and to always keep you informed about the present load situation.

A mechanical or electrical system on the vehicle maintains a fixed level of the chassis height through a level valve which adds or subtracts compressed air to the bellows according to the actual load on the vehicle.

The top of the bellow, shock absorber and the level valve are all fixed on the chassis of the vehicle.

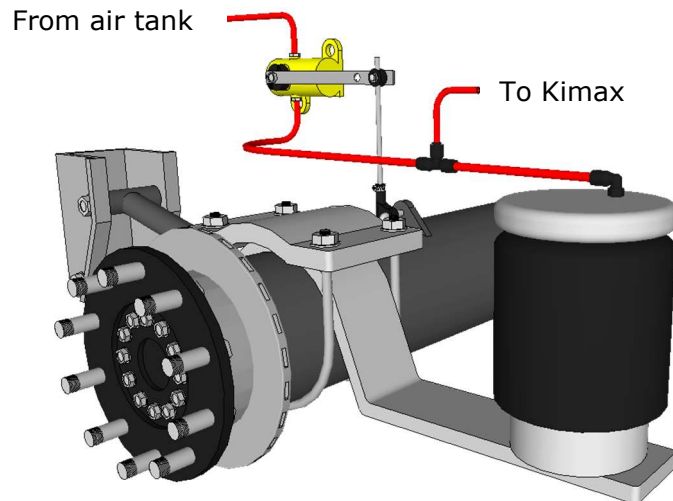

The pressure in the suspension system represents the weight of the axle/axle group.

The weight of the vehicle is a linear function of the pressure in the suspension system, see the chart on page 12.

The Kimax 1 instrument is customized to your vehicle by means of giving in the actual unloaded weight in tons when the truck is empty and giving in actual loaded weight in tons when the truck is loaded.



Both values, one for an empty vehicle (Lo) and one for a loaded vehicle (hi) MUST be entered into the Kimax unit when the pressure in the air suspension is present!

The accuracy of the weighing system is affected by the mechanical condition of your vehicle, e.g. the condition of the shock absorbers.

The Kimax instrument is not a verified weighing system.

Basic Kimax 1 installation

A Single air inlet channel is used on vehicles with combined level control for one or more axles.

In case of uneven load from one side to the other the pressure will slowly be equalized between the bellows in each side.

The reading on the Kimax unit will be correct when the pressure is equalized.

This application is used for measuring the axle load of a rear axle.

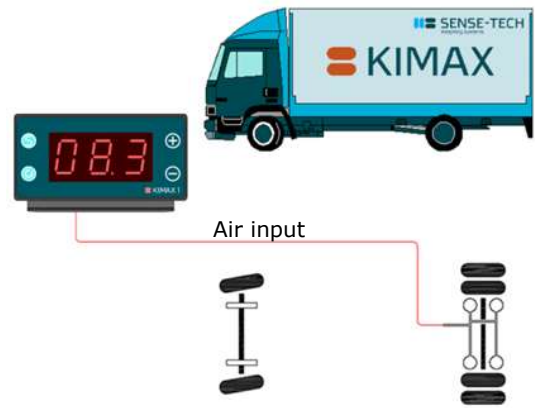

A dual air inlet channel is used on vehicles with split level control for one or more axles.

The Kimax unit calculates the weight using the air pressure from each side. In case of uneven load, the Kimax will show the correct axle load immediately after loading.

This application is ideal for measuring the axle load of a rear axle.

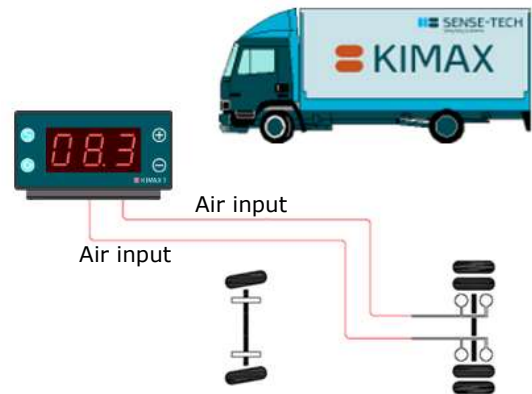

A dual air inlet can be applied on vehicles with one or more individual axles arranged in a combined level control system.

Using a Kimax 1 on two or more individual axles offers you a limited accuracy, because the measuring of the load depends on the center of gravity for the entire load - for better accuracy we recommend our Kimax 2 product group.

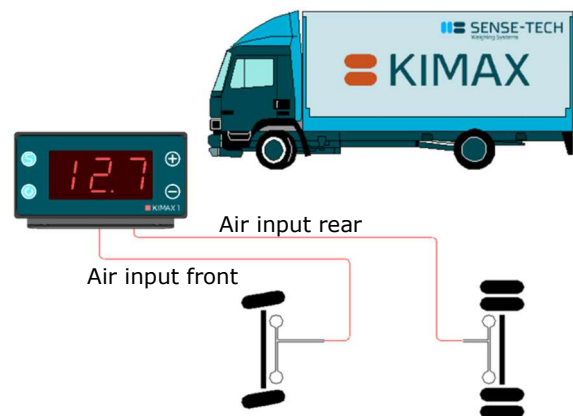

For more information please visit:

www.kimax.com



Air sensor installation

Connection of compressed air

Before you carry out any installation work related to the air suspension, make sure that the suspension has been brought to the lowest possible position and all compressed air is released.

First step in the installation is to identify the hose supplying compressed air to the bellows. This hose, typically 8 mm outer diameter, must be cut through and assembled once again with the T-piece supplied with the Kimax instrument.

The 6 mm output port of the T-piece has to be connected to the Kimax instrument according to the illustration on the next page.

It is important to install the hoses in such a way that they are not affected by other components. The hoses must be fixed at suitable intervals.

Route the hoses in such a way that they are not exposed to exhaust heat and other heating sources that may lead to the permissible temperature being exceeded.

Avoid damage from gravel, friction and contact with sharp edges.

Avoid excessive tension of the hoses.

Make sure that the smallest bending radius is not exceeded.

Make sure there is no leakage at the fittings, it will affect the accuracy of the measurement.

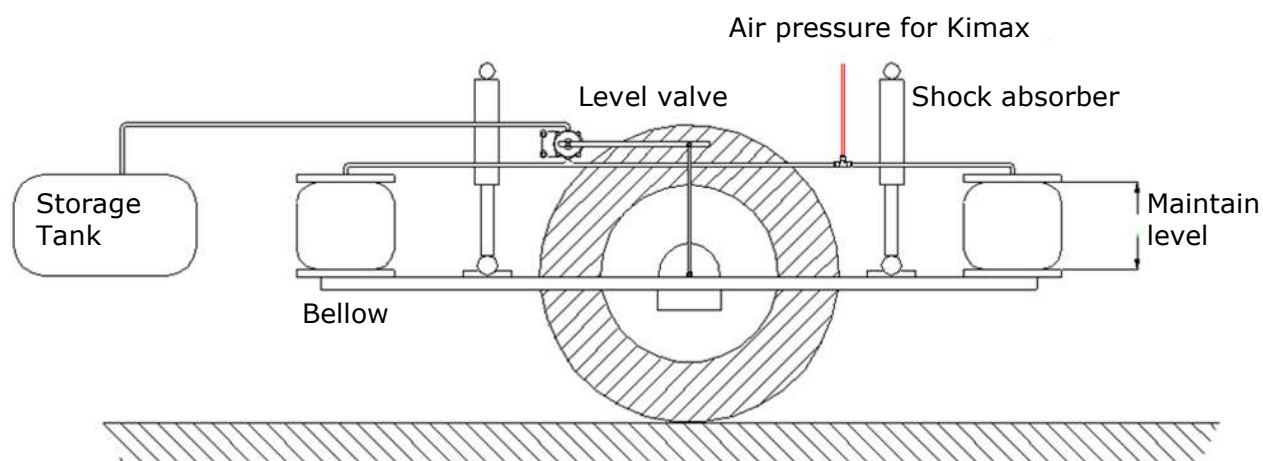

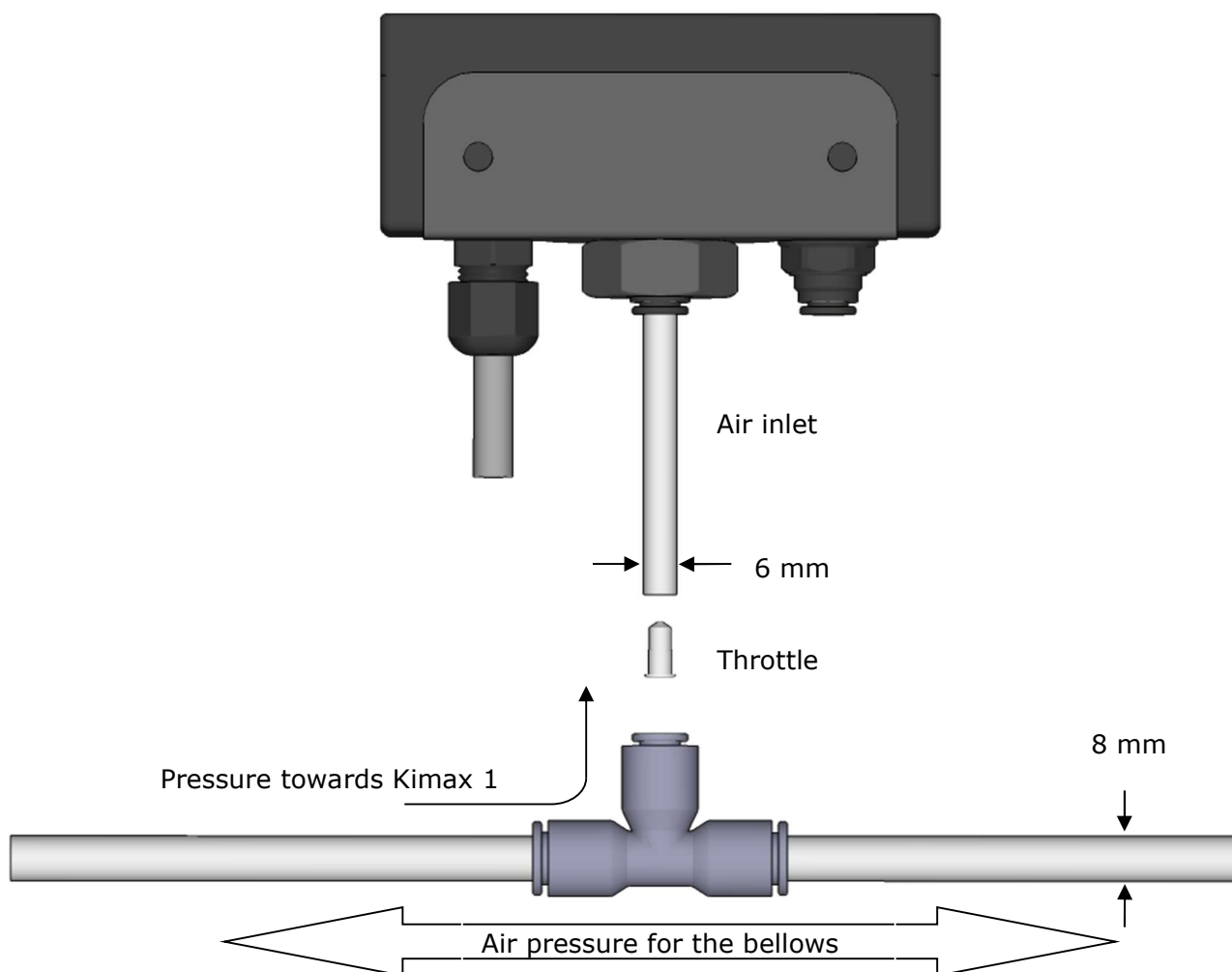

The Kimax instruments are equipped with push-in fittings.

You must make a clean perpendicular cut with a sharp knife or a hose cutter before you connect a new air hose to a Kimax instrument.

You can release the locking mechanism in the fitting by pushing-in the release ring.

(A 7 mm open-ended spanner is a suitable tool for pushing-in the release ring so you can pull out the air hose).

Sensor layout on different vehicles

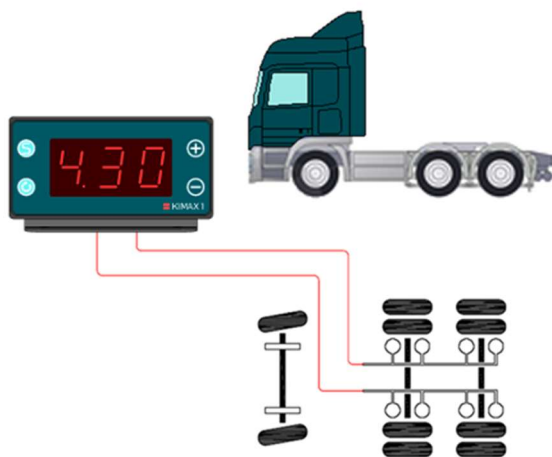
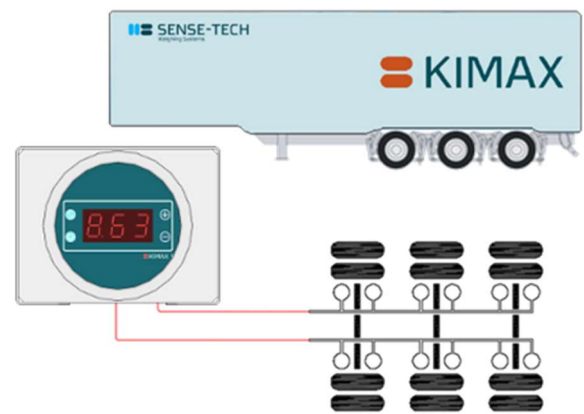
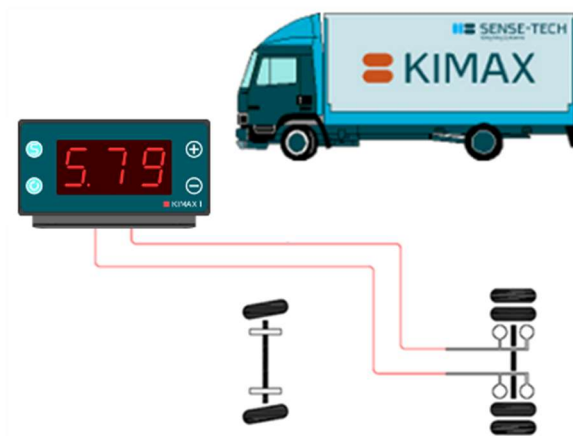
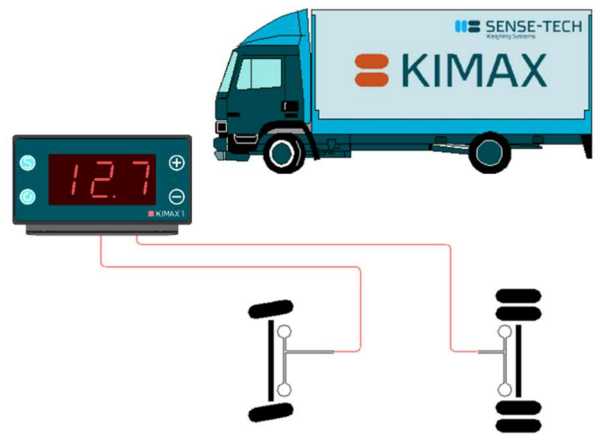
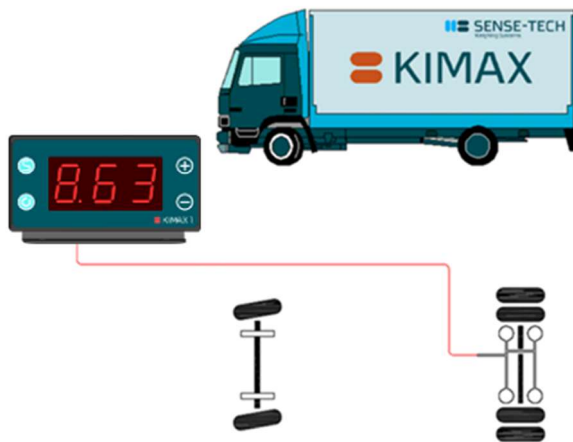

Hydraulic installation on a forklift

The hydraulic sensor is connected as indicated in this illustration.

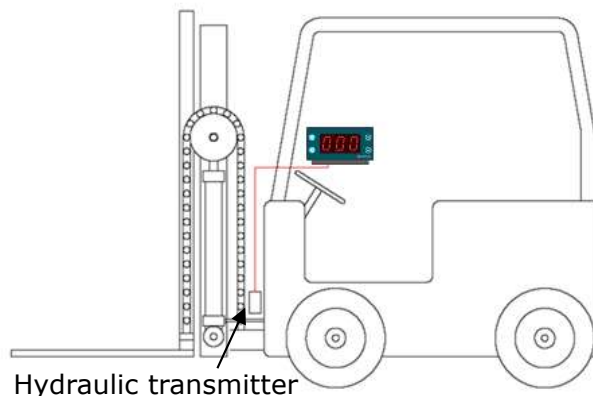
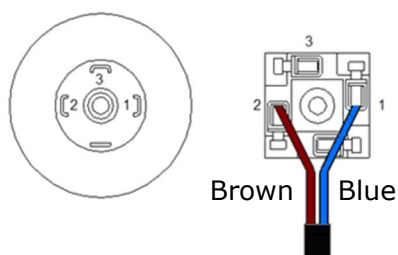



The hydraulic transmitter should be placed as close to the lifting cylinder as possible to obtain the best measuring accuracy.



Setting the Lo calibration point (Kimax 1 Hydraulic)

Raise the forks approx. 20 cm from the ground and lower them again approx. 5 cm.



Enter the menu on the Kimax by pressing  for approx. 4 secs (see page 11). Release the button and the display shows **in**. Press  twice and the display shows **Lo**.

Press  again and the display shows the value saved as **Lo**.

In case you want to skip/bypass the **Lo** calibration, press , now the display shows **hi** and the previous value has not been modified.

To change the **Lo** calibration, you may change the value by pressing  or  until you have the value that equals the readout you want when the pressure in the lift cylinder is like the present pressure.

Example 0.00



You save the value by pressing  when the Kimax saves the value, the display shows **-S-**. Press  to continue to **hi**.



Setting the hi calibration point (Kimax 1 Hydraulic)

Raise the forks approx. 20 cm from the ground with a known weight (the best accuracy is obtained if the load weighs close to the maximum lift capacity) and lower approx. 5 cm again.

Press  and now the display shows the value saved as **hi**.

In case you want to skip/bypass the **hi** calibration, press , now the display shows **AdL** and the previous value has not been modified.

To change the **hi** calibration, you may change the value by pressing  or  until you reach the value that equals the weight of the load.

You save the value by pressing  when the Kimax saves the value, the display shows **-S-**. Press  to continue to **AdL**.

During calibration you can modify **Lo** and **hi** in a sequence as described above or you can modify **Lo** or **hi** individually by bypassing the value you do not want to change by pressing  (see page 11).

Electrical installation

Electrical connection

Always disconnect the battery before you perform any installation work on the system of the vehicle.

Do not route the cables next to ignition cables or other cables carrying large currents.

Make sure that the cables are not exposed to tensile or shearing forces.

Protect the cables with rubber grommets if you route the cables through holes.

For connecting cables use crimp connectors or another approved method.

Avoid short-circuiting the system by faulty connections or squeezed cables.

Fasten the cables at suitable intervals.

Make sure all Kimax 1 instruments are protected with fuses in the supply cables.

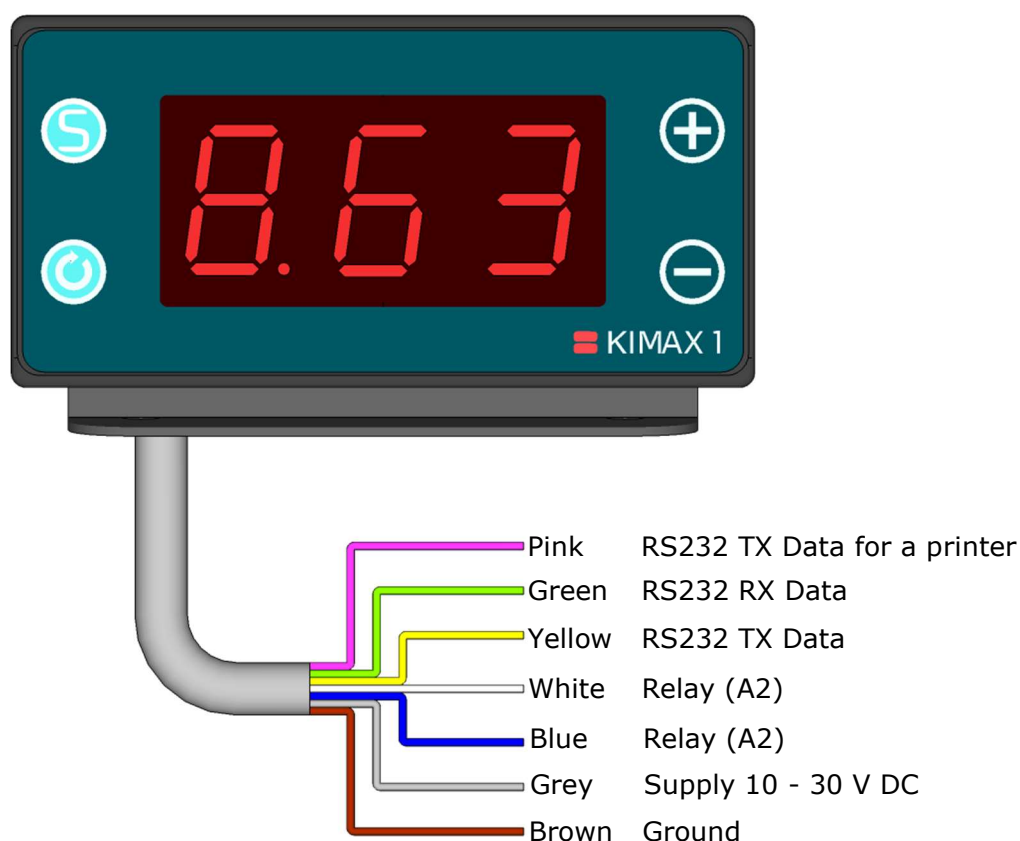

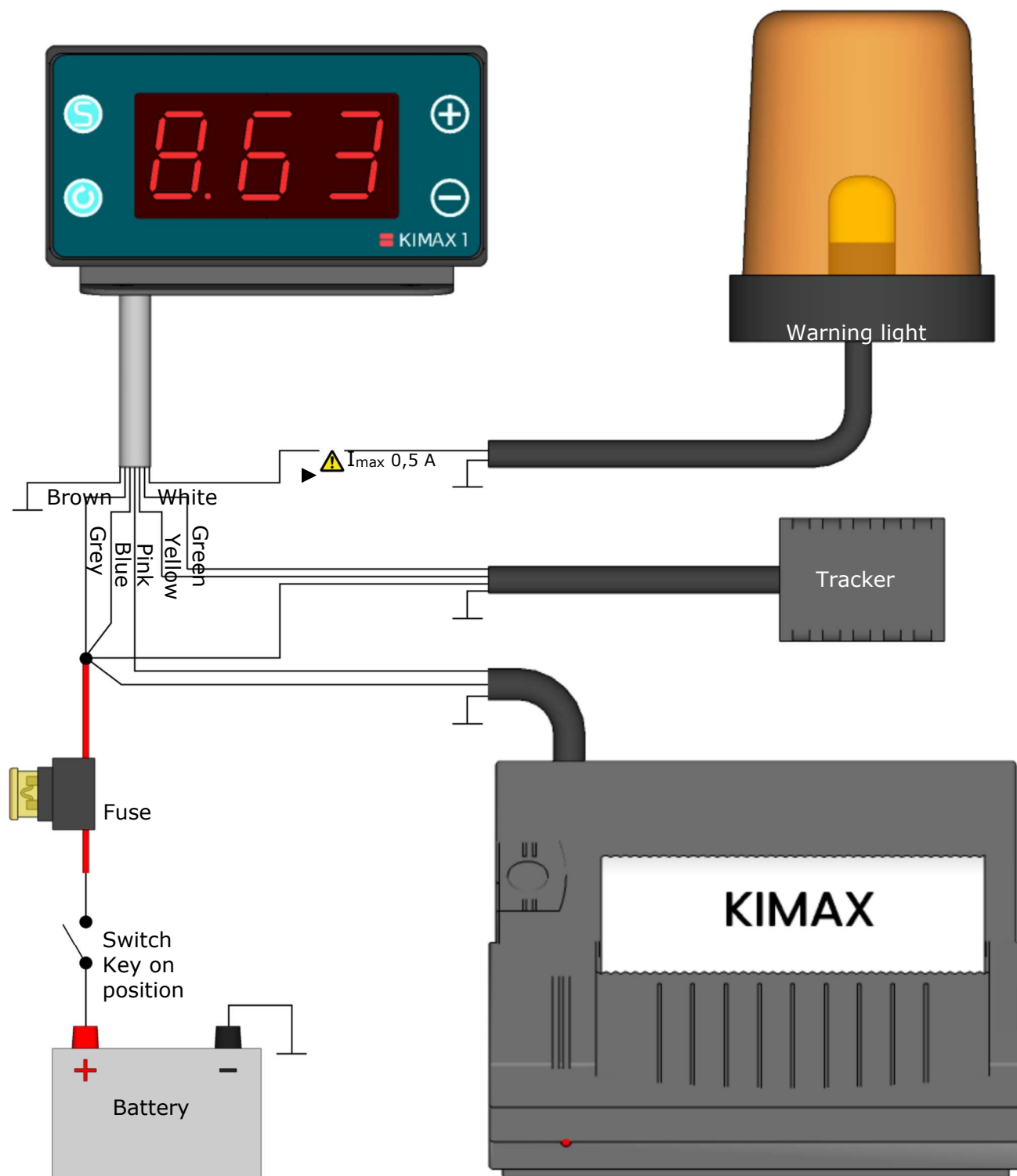

Optional: Warning light (A2), Tracker and Kimax printer.

Unused wires must be separately isolated.

Kimax 1 menu

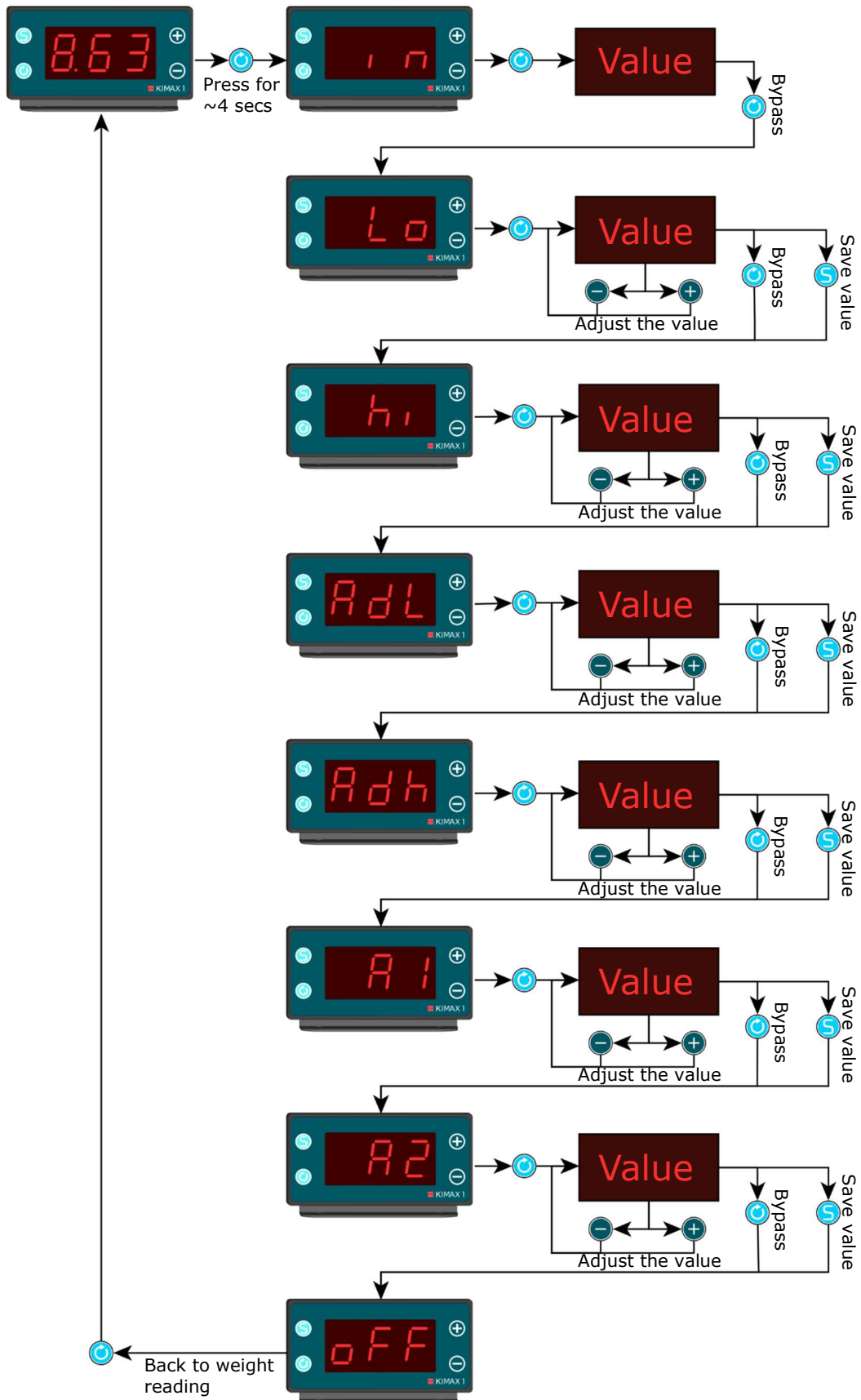

Input menu (in)

In the input menu it is possible to read the present signal from the sensor.

A hydraulic transmitter input produces a value ranging from 0 - 100% (0 - 22,9 mA).

An air input will give you a reading ranging from 0 - 10,0 bar.

AdL menu

In the **AdL** menu it is possible to read the input value of the sensor input from when the **Lo** calibration was performed (stored sensor value at empty calibration).

When a **Lo** calibration is performed the Kimax unit automatically saves the **in** value from the sensor input as an **AdL** value.

Adh menu

In the **Adh** menu it is possible to read the input value of the sensor input from when the **hi** calibration was performed (stored sensor value at loaded calibration).

When a **hi** calibration is performed the Kimax unit automatically saves the **in** value from the sensor input as an **Adh** value.

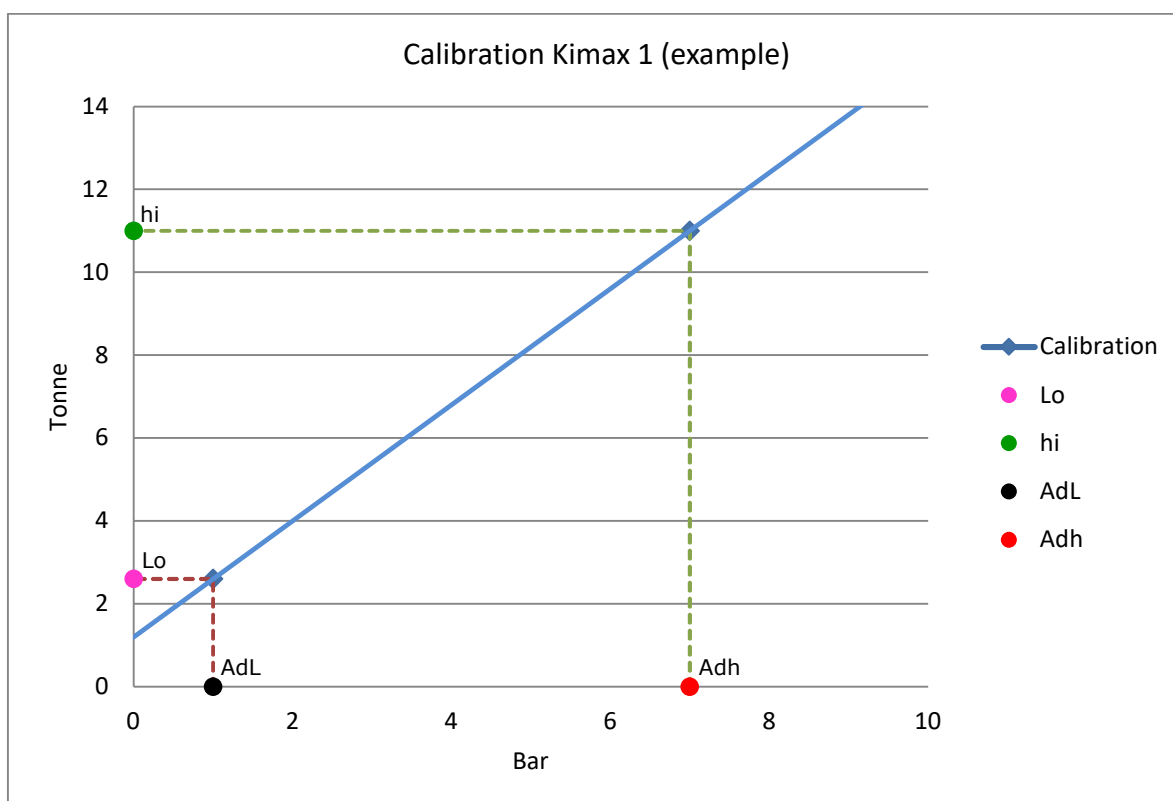



Calibration

Two reference values are needed to make a correct calibration, one value for the unloaded vehicle (**Lo**), and one for the loaded vehicle (**hi**). By means of these two reference values the Kimax 1 Axle Load Indicator will generate a complete pressure chart and display the current axle load on the display.

Setting the Lo calibration point



Go to a weighing bridge with your empty vehicle.



Enter the menu by pressing  for approx. 4 secs (see page 11). The display shows **in**.

Press  twice, now the display shows **Lo**.

Press  again and the value saved as **Lo** will be displayed.

In case you want to skip/bypass the **Lo** calibration, press , now the display shows **hi** and the previous value has not been modified.

To change the **Lo** calibration press  or , until you have the value that equals the readout from the weighing bridge.



You save the value by pressing . When the Kimax saves the value, the display shows **-S-**. Press  to continue to **hi**.



Setting the hi calibration point

Go to a weighing bridge with your loaded vehicle.

Press , and the display shows the value saved as **hi**.

In case you want to skip/bypass the **hi** calibration, press , now the display shows **AdL** and the previous value has not been modified.

To change the **hi** calibration press  or , until you have the value that equals the readout from the weighing bridge.

You save the value by pressing  when the Kimax saves the value, the display shows **-S-**. Press  to continue to **AdL**.

During calibration you can modify **Lo** and **hi** in a sequence as described above or you can modify **Lo** or **hi** individually by bypassing the value you do not want to change by pressing  (see page 11).



Weighing
bridge

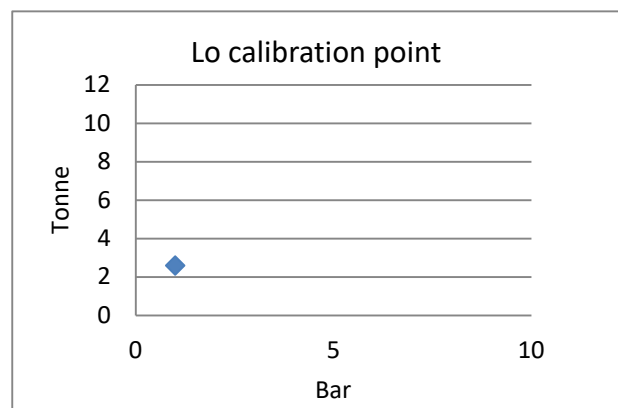

Weighing
bridge

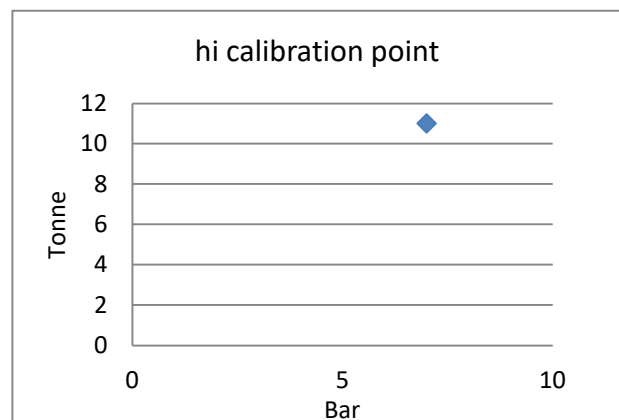

Alarms

The Kimax 1 has two different alarm functions.

When the weight reading exceeds the A1 alarm level, the three digits in the display start flashing.

When the weight reading exceeds the A2 alarm level, an internal relay connects the white and the blue wires in the supply cable (see page 9-10).

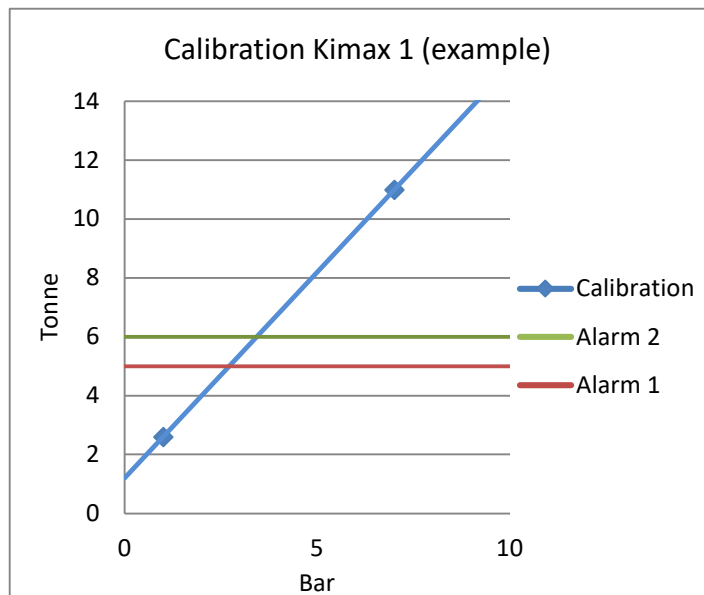

Setting the A1 alarm level



Enter the Kimax menu by pressing  for 4 sec. (see page 11).



Press  shortly several times until the display shows **A1**.

Press  once again, and the display shows the value saved as **A1**.

In case you want to maintain the present value, press  and the display shows **A2** without changing the **A1** value.

You can change the value by pressing  or  until you get a value equal to the alarm level you want.

You save the value by pressing . When the Kimax saves the value, the display shows **-S-**, press  and the display shows **A2**.

You leave the menu by pressing  shortly several times until the display shows **oFF** and then you press  once more or restart the Kimax.

Setting the A2 alarm level



Enter the Kimax menu by pressing  for 4 sec. (see page 11).

Press  shortly several times until the display shows **A2**.

Press  once again, and the display shows the value saved as **A2**.

In case you want to maintain the present value, press  and the display shows **oFF** without changing the **A2** value.



You can change the value by pressing  or  until you get a value equal to the alarm level you want.

You save the value by pressing . When the Kimax saves the value, the display shows **-S-**, press  and the display shows **oFF**.



You can leave the menu by pressing  or restart the Kimax.

Protect the calibration

Lock the Kimax 1

To lock the Kimax 1 and hereby prevent unintended changes to the calibration, activate  and  at the same time for 5 seconds, while the Kimax is powered. When the display switches off you may release the buttons. Now the display shows **-L-** and the Kimax is locked.

Unlock the Kimax 1

To unlock the Kimax 1 you must activate  and  at the same time for 5 seconds, while the Kimax is powered. When the display switches off you may release the buttons. Now the display shows **-u-** and the Kimax is unlocked.



Daily use

The Kimax 1 has four buttons and a display with three LED digits. The display is easy to read in a dark cabin and outside in bright sunlight.



When the unit starts up it shows **tot** and after 1 sec. the display shows the value of the currently measured weight of your vehicle/axle/axle group.

If you press  the display shows **PAY** and after 1 sec. the display shows the value of the payload of your vehicle/axle/axle group. **Payload** = **tot** value - **Lo** value

If you press the  button again, the display switches off. Press the button  again and you are back to **tot**.

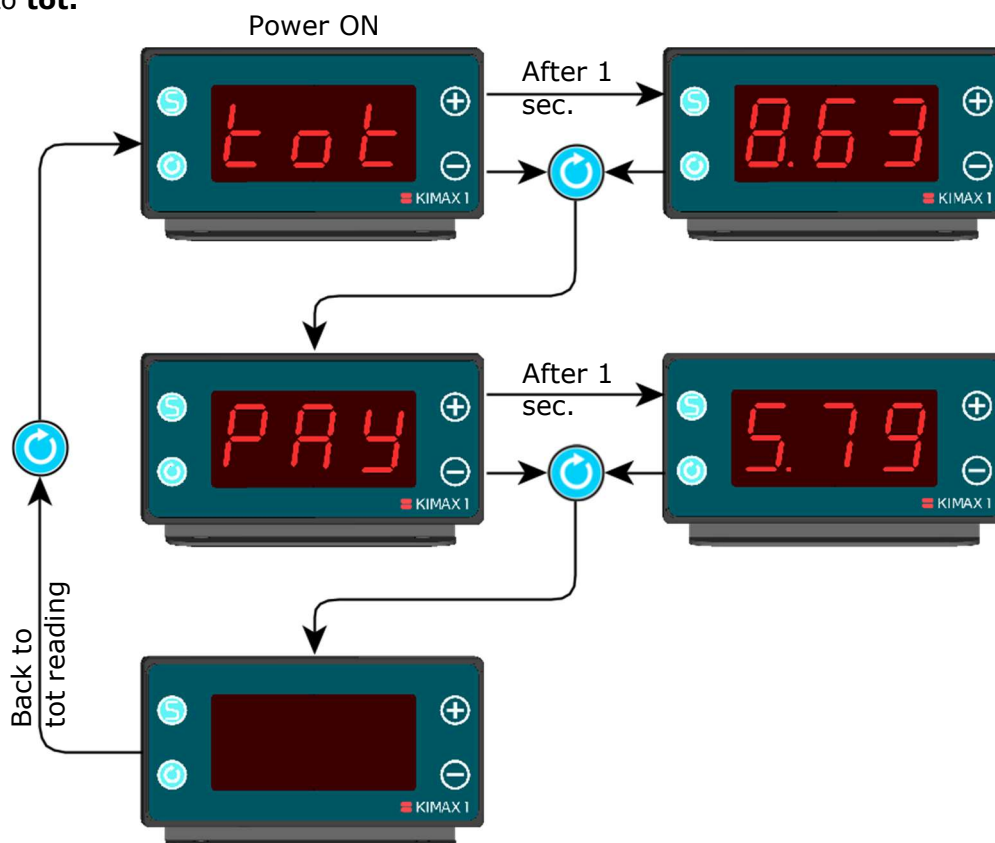

The Kimax instrument has a floating point. Values from 0.00 - 9.99 will be displayed with 2 digits after the decimal point. Values from 10.0 - 99.9 will be displayed with 1 digit after the decimal point. Values from 100 - 999 will be displayed without digits after the decimal point.

Serial output

OBC

The Kimax 1 instrument offers you a RS-232 serial output that broadcasts the measured **tot** value.

The string of data is broadcasted every 10th second and can be transmitted to a fleet management vehicle tracker.

To test the serial output, you can set up a "HyperTerminal" on a computer with the parameters below.

| | |
|-------------|-------|
| Bit pr sec | 9.600 |
| Data bit | 8 |
| Parity | N |
| Stopbit | 1 |
| Flowcontrol | N |

Now you will be able to read the broadcasted value as numeric characters.

You need to set up your fleet management vehicle tracker for receiving data with the same parameters.

The protocol looks like this:

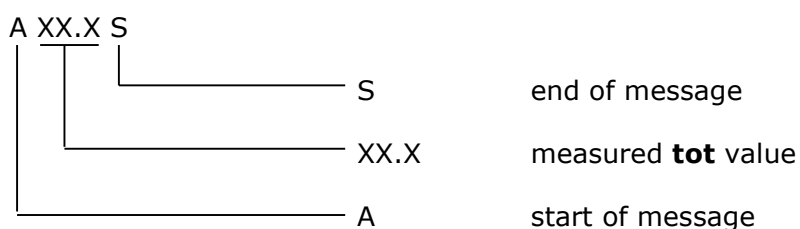

Printer

The Kimax 1 instrument offers you a RS-232 serial output for a printer.

The string of data is broadcasted every time you activate the print function on the instrument, by pressing  for 3 seconds.

As a test, you can set up a "HyperTerminal" on a computer with the parameters shown, and you can read the broadcasted data.



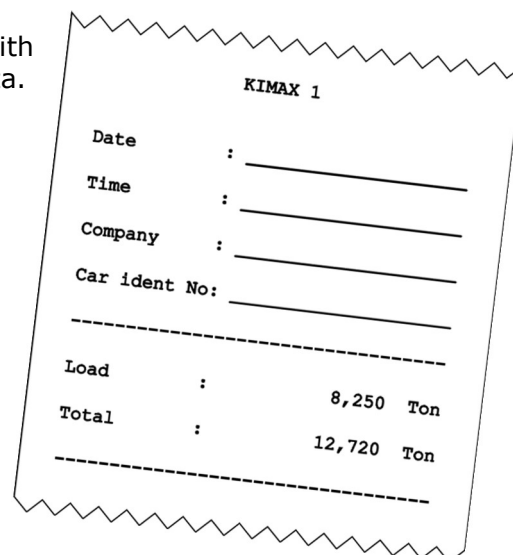

| | |
|-------------|-------|
| Bit pr sec | 4.800 |
| Data bit | 8 |
| Parity | N |
| Stopbit | 1 |
| Flowcontrol | N |

You need to set up your printer to receive data with the same parameters.

Most common printers with a serial input can be used with a Kimax 1 unit.

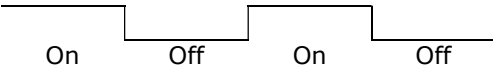
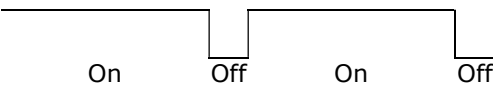

Troubleshooting

| Problem | Possible solution |
|--|--|
| Display is flashing like this...  | The value shown is below zero. |
| Display is flashing like this...  | When the tot value exceeds the value for A1, the display starts to flash. For more information on this function see page 11. |
| Display is blank | Press the  button to turn on the display. For more information on this function see page 16. or Check the wiring, see page 9 and 10. |
| The value shown oscillates/fluctuates.. | Check the air hose for leakage. Make sure the 0,4 mm hole in the throttle is not blocked. Check that the AdL and the Adh values are not equal (see page 12). Recalibrate the instrument. |
| The value shown is fixed | Check the air hose for leakage. Make sure the 0,4 mm hole in the throttle is not blocked. Check that the Lo and the hi values are not equal (see page 12). Recalibrate the instrument. |
| Calibration is not possible, the display shows -L-, when  or  is pressed.. | The unit is locked/protected from changes made in the memory. Check page 15 for unlocking the unit. |

If you don't find a solution to your issue, feel free to contact us.

Dimensions and technical specifications

Kimax 1 cabin version

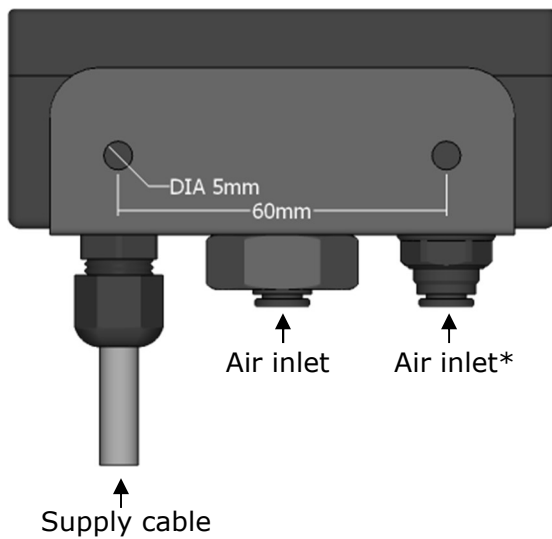
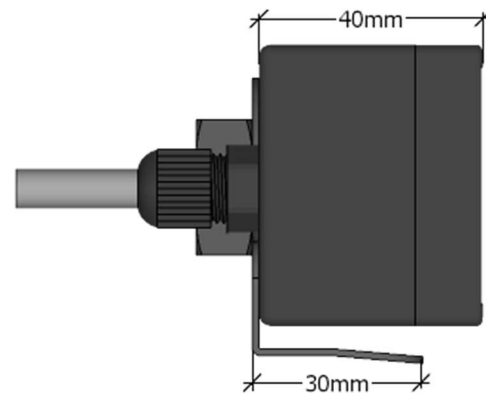
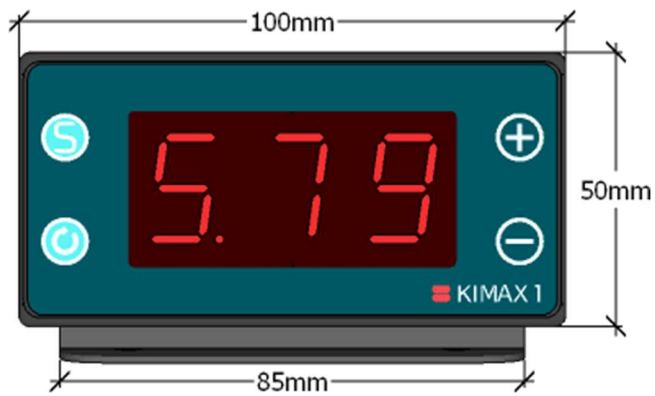

* Not present on single air inlet instruments

Kimax 1 Trailer version

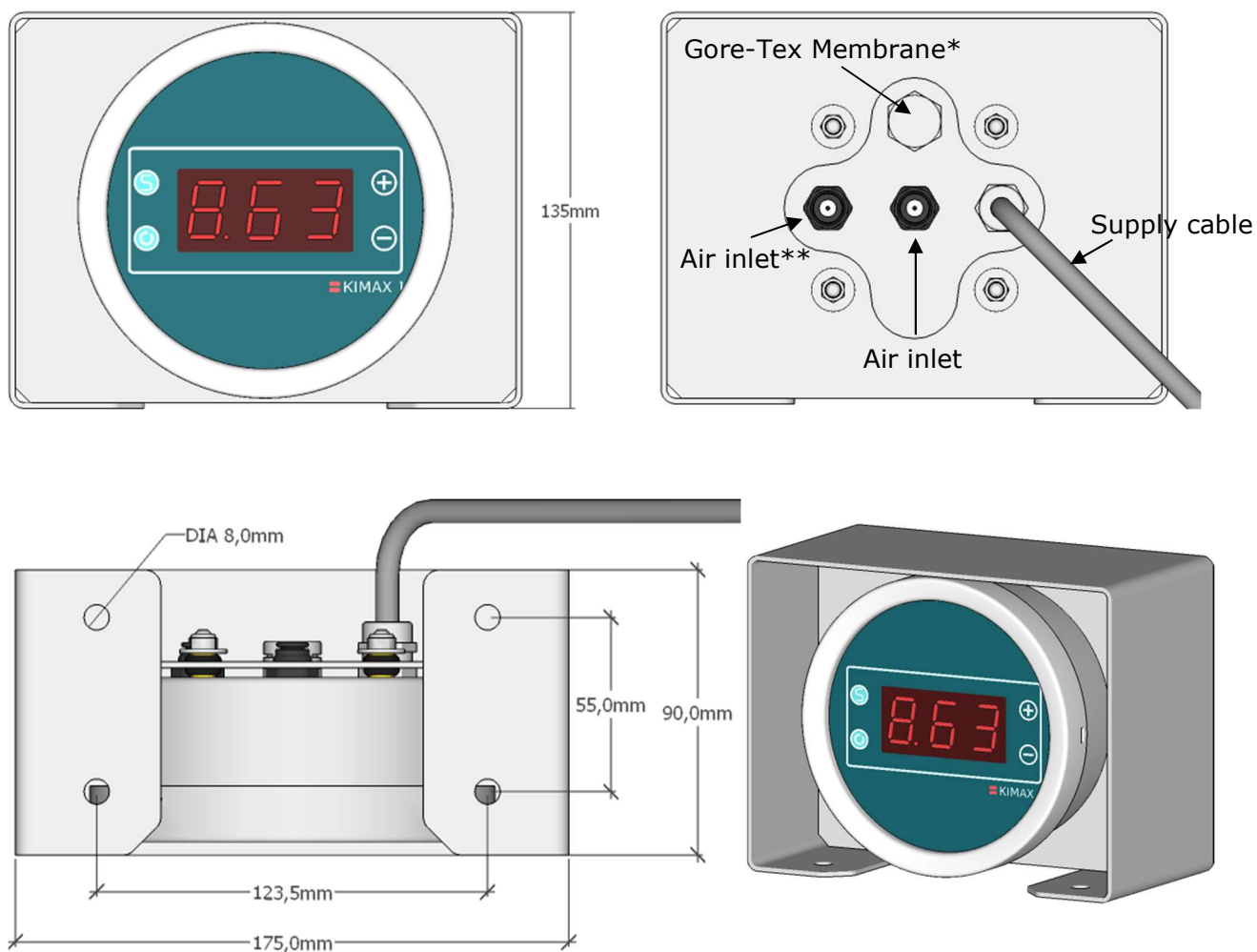

*The Gore-Tex membrane is for venting the Kimax 1 housing, to avoid getting vacuum in the housing during shifting ambient temperatures.

The Gore-Tex membrane is only present on the trailer versions of the Kimax 1 instruments.

If you paint the instrument, make sure the venting opening in the Gore-Tex membrane is not blocked with paint. Cover it with painter's tape before painting.

** Not present on single air inlet instruments. On single air inlet instruments the Gore-Tex membrane is placed here.

Kimax 1 OEM Trailer version

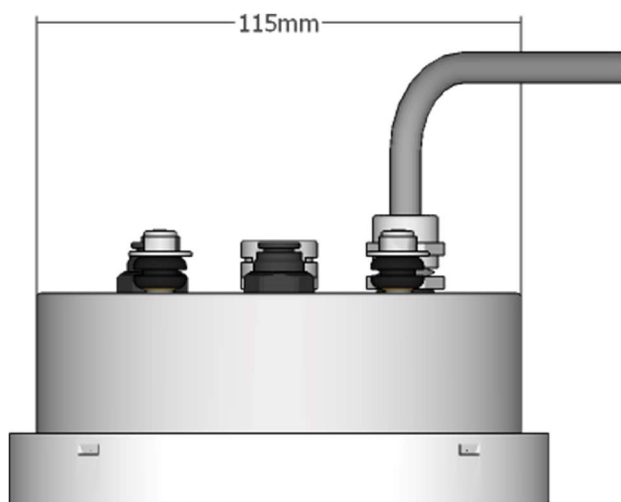
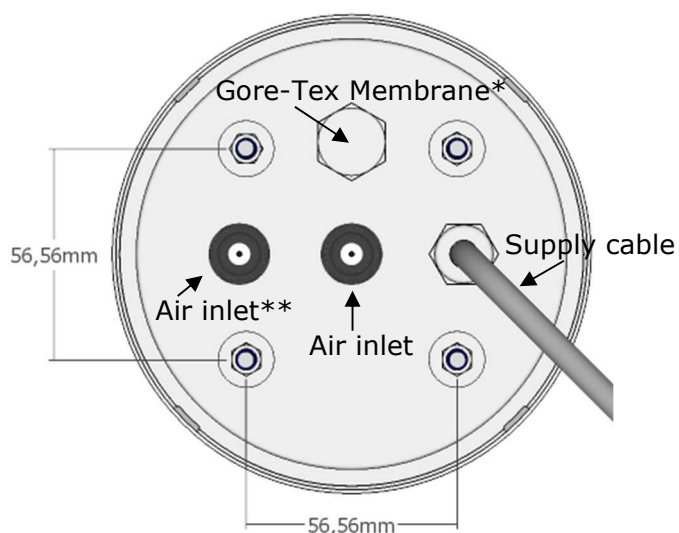

*The Gore-Tex membrane is for venting the Kimax 1 housing, to avoid getting vacuum in the housing during shifting ambient temperatures.

The Gore-Tex membrane is only present on the trailer versions of the Kimax 1 instruments.

If you paint the instrument, make sure the venting opening in the Gore-Tex membrane is not blocked with paint. Cover it with painter's tape before painting.

** Not present on single air inlet instruments. On single air inlet instruments the Gore-Tex membrane is placed here.

Technical specification Kimax 1 cabin

| | |
|-----------------------|---|
| Supply voltage | 10 ... 30 Volt direct current |
| Current consumption | max. 90 mA |
| Alarm 1 | Flashing display |
| Alarm 2 | NO relay contact max. 0.5 A/30 VDC |
| Display | Three-digits 7-segment LED, character height 20.3 mm |
| Decimal position | 000. / 00.0 / 0.00 (floating point) |
| Measuring accuracy | ±2 % of maximum load at 0 °C ... +50 °C |
| Air connection | Quick release connection, 6 mm hose |
| Maximum pressure | 15.5 bar (225 psi) |
| Operating pressure | Range 0 to 10.5 bar (0 to 150 psi) |
| Operating temperature | -25 °C ... +70 °C |
| Storage temperature | -40 °C ... +70 °C |
| Dimensions | 100 x 50 x 40 mm |
| Cable length | 1,5 m - 7 x 0,34 mm ² |
| Weight | approx. 240 g |
| Imperviousness | IP 60 |
| Approval | CE and E1 |

Set includes:

Kimax 1 cabin 2 sensors

Part number 012000-0101
 1 x display unit, cabin
 1 x mounting bracket
 2 x angle fittings
 2 x air pressure throttle dia. 6mm
 2 x T-fitting dia. Ø 8mm / 6mm / 8mm

Kimax 1 cabin 1 sensor

Part number 011000-0101
 1 x display unit, cabin
 1 x mounting bracket
 1 x angle fittings
 1 x air pressure throttle dia. 6mm
 1 x T-fitting dia. Ø 8mm / 6mm / 8mm

Technical specification Kimax 1 trailer

| | |
|-----------------------|---|
| Supply voltage | 10 ... 30 Volt direct current |
| Current consumption | max. 90 mA |
| Alarm 1 | Flashing display |
| Alarm 2 | NO relay contact max. 0.5 A/30 VDC |
| Display | Three-digits 7-segment LED, character height 20.3 mm |
| Decimal position | 000. / 00.0 / 0.00 (floating point) |
| Measuring accuracy | ±2 % of maximum load at 0 °C ... +50 °C |
| Air connection | Quick release connection, 6 mm hose |
| Maximum pressure | 15.5 bar (225 psi) |
| Operating pressure | Range 0 to 10.5 bar (0 to 150 psi) |
| Operating temperature | -25 °C ... +70 °C |
| Storage temperature | -40 °C ... +70 °C |
| Dimensions | 175 x 135 x 90 mm |
| Cable length | 1,5 m - 7 x 0,34 mm ² |
| Weight | approx. 1650 g |
| Imperviousness | IP 65 |
| Approval | CE and E1 |

Set includes:

Kimax 1 trailer 2 sensors

Part number 022000-0101
 1 x display unit, trailer
 1 x 2 mm stainless-steel frame
 2 x angle fittings
 2 x air pressure throttle dia. 6mm
 2 x T-fitting dia. Ø 8mm / 6mm / 8mm

Kimax 1 trailer 1 sensor

Part number 021000-0101
 1 x display unit, trailer
 1 x 2 mm stainless-steel frame
 1 x angle fittings
 1 x air pressure throttle dia. 6mm
 1 x T-fitting dia. Ø 8mm / 6mm / 8mm

Technical specification Kimax 1 cabin - hydraulic

| | | |
|-----------------------|---|--|
| Supply voltage | 10 ... 30 Volt direct current | Set includes: Kimax 1 hydraulic Part number 015000-0103 1 x display unit, cabin 1 x mounting bracket 1 x ½" to 3/8" adapter |
| Current consumption | max. 90 mA | |
| Alarm 1 | Flashing display | |
| Alarm 2 | NO relay contact max. 0.5 A/30 VDC | |
| Display | Three-digits 7-segment LED, character height 20.3 mm | To be ordered separately 1 x Hydraulic transmitter ½" inlet |
| Decimal position | 000. / 00.0 / 0.00 (floating point) | |
| Measuring accuracy | ±2 % of maximum load at 0 °C ... +50 °C | |
| Maximum pressure | Depends on the connected transmitter | |
| Operating pressure | | |
| Operating temperature | Depends on the connected transmitter | |
| Storage temperature | -25 °C ... +70 °C | |
| Dimensions | -40 °C ... +70 °C | |
| Cable length | 100 x 50 x 40 mm | |
| Weight | 1,5 m - 7 x 0,34 mm ² | |
| Imperviousness | approx. 240 g + 250 g sensor | |
| Approval | IP 60 CE and E1 | |

Technical Specifications Kimax 1 OEM trailer

| | | |
|-----------------------|---|--|
| Supply voltage | 10 ... 30 Volt direct current | Set includes: Kimax 1 OEM trailer 2 sensors Part number 022000-9101 1 x display unit, trailer 2 x angle fittings 2 x air pressure throttle dia. 6mm 2 x T-fitting dia. Ø 8mm / 6mm / 8mm |
| Current consumption | max. 90 mA | |
| Alarm 1 | Flashing display | Kimax 1 OEM trailer 1 sensor Part number 021000-9101 1 x display unit, trailer 1 x angle fittings 1 x air pressure throttle dia. 6mm 1 x T-fitting dia. Ø 8mm / 6mm / 8mm |
| Alarm 2 | NO relay contact max. 0.5 A/30 VDC | |
| Display | Three-digits 7-segment LED, character height 20.3 mm | |
| Decimal position | 000. / 00.0 / 0.00 (floating point) | |
| Measuring accuracy | ±2 % of maximum load at 0 °C ... +50 °C | |
| Air connection | Quick release connection, 6 mm hose | |
| Maximum pressure | 15.5 bar (225 psi) | |
| Operating pressure | Range 0 to 10.5 bar (0 to 150 psi) | |
| Operating temperature | -25 °C ... +70 °C | |
| Storage temperature | -40 °C ... +70 °C | |
| Dimensions | 175 x 135 x 90 mm | |
| Cable length | 1,5 m - 7 x 0,34 mm ² | |
| Weight | approx. 700 g | |
| Imperviousness | IP 65 | |
| Approval | CE and E1 | |

The policy of Sense-Tech Weighing Systems ApS is to continually improve our products. This means that product specifications may change without prior notice.

Kimax 1 & Kimax 2 are registered trademarks owned by Sense-Tech Weighing Systems ApS.

Declaration of Conformity



Kimax 1

We declare under Sole responsibility that the product described under technical specification is in conformity with the following standards or standardization documents:
ECE R10, item 6.5 – 6.6 - 6.7 - 6.8 – 6.9

Technical file at Sense-Tech Weighing Systems ApS, DK-7173 Vonge

Erik Kjærsgaard
Director
Vonge 29. May 2018

